

# A promising and low-cost prototype to evaluate the motor pattern of nutritive and non-nutritive suction in newborns

Manuel Cunha<sup>1,2</sup>, João Barreiros<sup>2</sup>, José Miguel Pereira<sup>3</sup>, Vítor Viegas<sup>3</sup>, Carlos Banha<sup>3</sup>, Ana Diniz<sup>2</sup>, Margarida Pereira<sup>4</sup>, Rosalina Barroso<sup>1</sup>, Helena Carreiro<sup>1</sup>

<sup>1</sup>Neonatal Intensive Care Unit, Hospital Prof. Dr. Fernando Fonseca EPE, Amadora, Portugal

<sup>2</sup>Faculty of Human Kinetics, Universidade de Lisboa, Lisboa, Portugal

<sup>3</sup>LabIM, Escola Superior de Tecnologia de Setúbal, Instituto Politécnico de Setúbal, Setúbal, Portugal

<sup>4</sup>Centro Hospitalar de Lisboa Ocidental, Hospital São Francisco Xavier, Lisboa, Portugal

## Abstract

**Introduction:** Non-nutritive sucking (NNS) plays an important role in stabilizing the preterm, providing oral muscle training opportunity for nutritive sucking (NS). We aim to determine if the prototype tested allows a precise evaluation of suction pattern characteristics (rhythmic structure and pressure). We also aim to investigate the role of maturation in the variation of NNS an NS pattern in preterm infants.

**Methods:** The patented prototype is non-invasive, low-cost and easily applicable to clinical ecological practice, measures the pressure exerted on a pacifier in newborn's mouth. Samples were acquired continuously during a 10-minute period in 12 preterm (mean gestational age [GA]  $29.9 \pm 1.6$  weeks) and 4 term neonates (GA  $39.5 \pm 1.4$  weeks). Bursts, suctions per burst, pauses, suction frequency and pressure were analyzed to describe temporal structure and dynamic characteristics of NNS.

**Results:** The NNS pattern was characterized by bursts duration  $4.3 \pm 2.2$  s, number of sucks per burst  $7.4 \pm 3.2$ , sucking frequency  $2.1 \pm 0.4$  Hz and sucking pressure  $10.3 \pm 4.5$  mmHg. There were significant differences between the preterm and term groups in NNS sucking frequency ( $2.1$  Hz vs  $1.6$  Hz;  $p = 0.008$ ).

**Conclusion:** The device is non-invasive and can easily be used in clinical practice in low GA newborns, in an ecological environment. It allows the evaluation of NNS patterns maturation and, at the same time, the use of the device pacifier promotes NNS, which is important in the process of acquiring feeding autonomy in preterm infants.

## Keywords

Newborn, non-nutritive sucking, preterm, prototype, pressure measurement.

## Corresponding author

Manuel Cunha, Unidade de Neonatologia, Hospital de Cascais Dr José de Almeida, Av. Brigadeiro Victor Novais Gonçalves, 2755-009 Alcabideche, Portugal; e-mail: manuelsousacunha@gmail.com.

## How to cite

Cunha M, Barreiros J, Pereira JM, Viegas V, Banha C, Diniz A, Pereira M, Barroso R, Carreiro H. A promising and low-cost prototype to evaluate the motor pattern of nutritive and non-nutritive suction in newborns. *J Pediatr Neonat Individual Med.* 2019;8(2):e080220. doi: 10.7363/080220.

## Introduction

The organization of suction in a structured and stable pattern is an implicit condition for hospital discharge for preterm infants, as feeding autonomy depends on this skill. The suction pattern is a complex motor behaviour as well as a critical requirement for survival and well-being, and its evaluation can provide important clues to the integrity of the central nervous system [1-3].

The presence of suction behaviour can be observed from 28 weeks onwards, but it is more stable after 34 weeks [4-7]. Using a soft pacifier, a primitive non-nutritive sucking (NNS) can be triggered in premature infants by 26 weeks gestational age (GA) [8]. However, rhythmic stability is only observed after 30 weeks, with sucking activity increasing with GA, from 30 to more than 36 weeks postconceptional age (PCA) [1, 6]. In full-term newborns, the rhythm is fully competent 5 minutes after birth [3].

The evaluation of sucking competence is most often performed by clinical observation based on the experience of the health team, thus being very dependent on that same experience. Scales, such as NOMAS, [9] or Early Feeding Scale (EFS) [10], are also used, either in their complete form or using a limited number of items, such as Non-Nutritive Sucking Score System [11].

Although nutritive sucking (NS) and NNS appear to be two independent processes (for example, they have different suction frequencies) [12], the possible central pattern generators, psychophysiological regulation and mechanical movement themselves may present common traits [13]. There are several studies to demonstrate the positive influence of NNS stimulation on the improvement of the NS pattern and suction

efficiency, with impact on earlier feeding autonomy and shorter hospital stays [13-17].

The direct measurement of the NS pattern has some drawbacks and limitations, namely the need for sophisticated, invasive and expensive equipment [14, 18, 19]. On the other hand, clinical evaluation scales, such as NOMAS and EFS, require specific training for their application, and involve many human resources [9, 10]. A suitable alternative is to extract this information using pacifier instrumentation, which allows inference for NS on the breast or nipple.

In order to address these limitations, we present a NNS measurement prototype, that is non-invasive, easily applicable to clinical practice and inexpensive, and which can be used in ecological clinical conditions. This device can be used even in the Baby-Friendly Hospital Initiative context, as the use of a pacifier as NNS stimulation is authorized in preterm infants [13-17]. The main aim is to determine if the developed prototype allows the precise evaluation of the main characteristics of the suction pattern, including the rhythmic structure and pressure characteristics. As secondary aims, we attempt to investigate the role of maturation in the variation of the NNS pattern in preterm infants, and also to observe the correlation between NNS and NS patterns.

## Methods

The present study is a cross-sectional, descriptive study of rhythmic patterns and suction pressure dynamics in a convenience sample of 12 preterm infants between 32-36 weeks PCA and 4 term newborns, between 37-41 weeks GA, as suction reference standards. The sucking experience was considered as the time the newborn was placed with oral stimulation on the breast or bottle. The assessment point was within 30 minutes prior to feeding, when the newborn was in an alert state.

The following exclusion criteria of preterm babies were oxygen dependence at 36 weeks, intraperiventricular haemorrhage higher than grade II. In both groups, newborns were excluded if they had central nervous system malformations, chromosomal anomalies or polymalformative syndromes, intrauterine growth restrictions, or asphyxia defined by an Apgar score lower than 5 at 5 minutes of life.

An exploratory study was conducted on the application of a prototype developed by the Department of Instrumentation and Measurement, at ESTS/IPS (Escola Superior de Tecnologia de Setúbal,

Instituto Politécnico de Setúbal, Setúbal, Portugal), whose patent has been registered. The system measures the pressure exerted on the dummy placed in the mouth of the newborn with an acquisition sample rate of 10 samples/second and is a minimally invasive measurement device. The proposed solution is adapted to a common commercial pacifier like those that are used in most of the paediatric and neonatal units. The characteristics of the measuring system do not introduce any changes in NNS patterns and dynamics.

Simultaneously, the absence of sensors, components or electrical interconnections inside the pacifier mouthpiece ensures safety conditions

that are not present in systems of the same type in which the sensor, although insulated (silicone), is placed inside the mouth of the premature infant. In this solution, the suction pressure is transmitted pneumatically by means of a low section silicone tube, which is connected to the mouthpiece of the pacifier, and the metering system is placed remotely. This flexible silicone tube (the fluid system used in Neonatal Intensive Care Units [NICUs]) interconnects the pressure sensor, from the measuring system to the pacifier. The signal from the pressure sensor is amplified and filtered and then digitized by a BIOPAC A/D converter (MP 100) (Fig. 1).

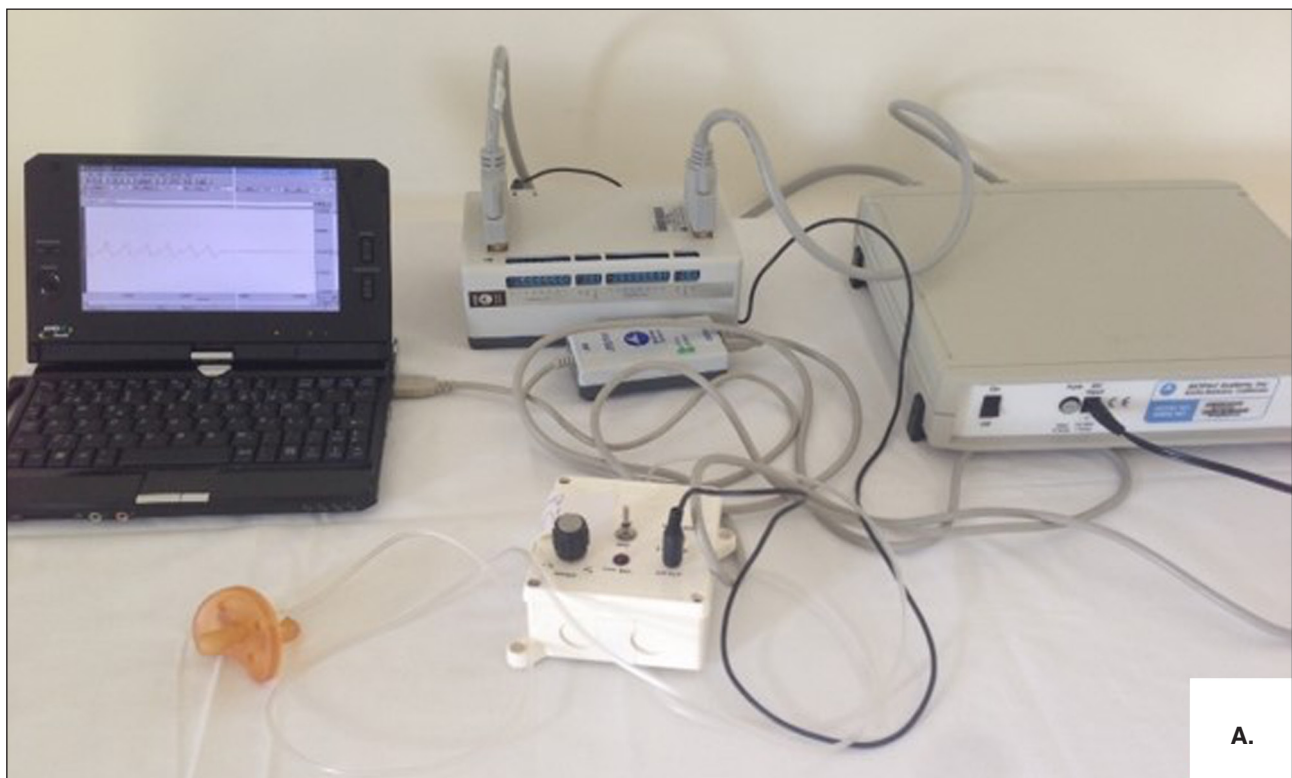

**Figure 1.** A. Prototype with the pacifier connected to the pressure sensor and BIOPAC A/D converter. B. Pacifier adaptation for non-nutritive sucking (NNS) measurement. C. Pacifier adaptation for nutritive sucking (NS) measurement.

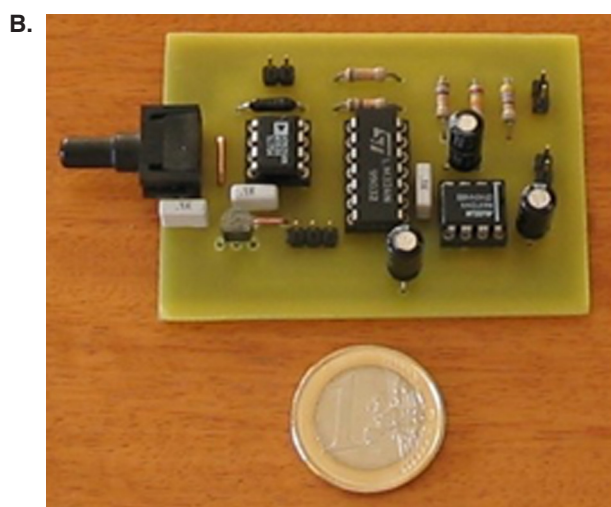
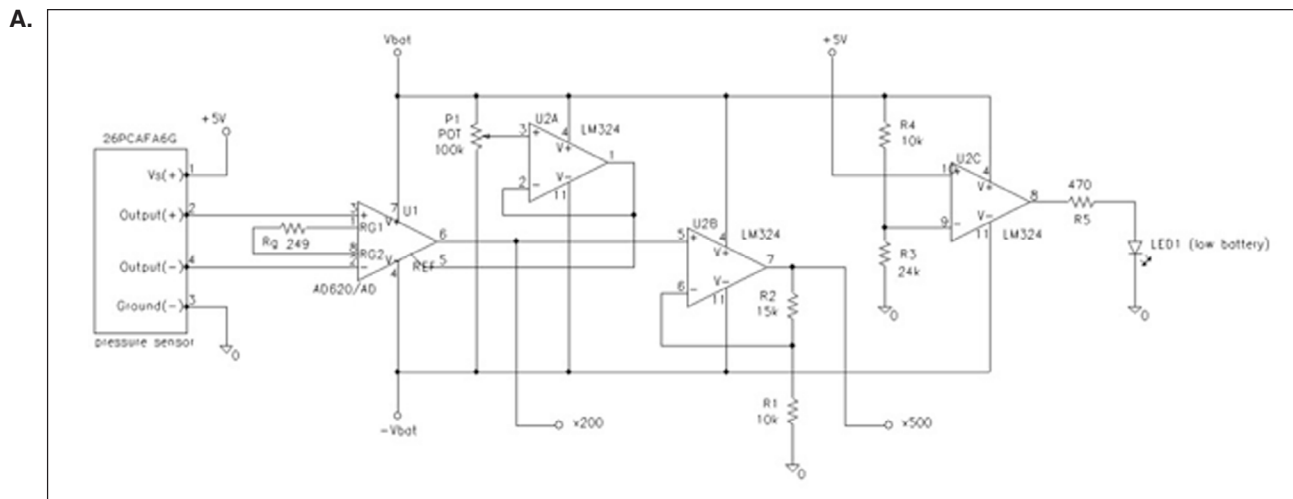

**Figure 2.** A. Schematic diagram of the measurement system. B. Printed circuit board and components.

## Measurement system

### Description

The measurement system includes a pressure sensor, model 26PCAF6G by Honeywell [20], followed by a two-stage amplifier circuit (see Fig. 2). The sensor picks up the pressure generated by the pacifier and converts it into a voltage. The main characteristics of the sensor include: a piezoresistive based working principle, a measuring range of  $\pm 1$  psi relative to atmospheric pressure (gauge pressure), a ratiometric output, an interval of 8.35 mV when supplied at 5 VDC, and linearity equal to 0.25% of the interval.

An instrumentation amplifier with a gain of 200, followed by a non-inverting amplifier with a gain of 2.5, is used to amplify the output signal delivered by the pressure sensor. The outputs of the amplifiers are both available: the first one goes from 0 to 1.670

V, while the second one goes from 0 to 4.175 V. The instrumentation amplifier allows offset adjustment by means of a multi-turn potentiometer.

### Calibration

In order to obtain the relationship between the voltage measured in the BIOPAC, which works with a unit gain, and the associated pressure value, the measurement system was calibrated in the laboratory. The equipment used in the calibration includes the measuring circuit, the sensor plus its conditioning circuit, a portable pneumatic tester [21], a hand-operated vacuum pump [22], a two-metre water column [23] and a precision digital multimeter. The pressure calibration accuracy was greater than 36.7  $\mu\text{mHg}$ .

The calibration results are represented in Fig. 3. Using a linear curve fitting of the calibration points, the following calibration characteristic is obtained:

$$V_0 = 48.99 \cdot p + 8.61 \text{ mV}$$

where  $V_0$  represents the output voltage of the conditioning circuit,  $p$  represents the input pressure in mmHg units, and the constant, 8.61 mV, is an offset deviation caused by the non-linearity error of the sensor plus conditioning circuit. This error is cancelled out by the BIOPAC system during the zero baseline adjustment.

The linearity of the measuring chain is experimentally confirmed, with a correlation coefficient, associated with the calibration points, that is almost equal to one ( $cc = 0.99996$ ).

Removing the offset component that results from calibration curve fitting, the relationship between



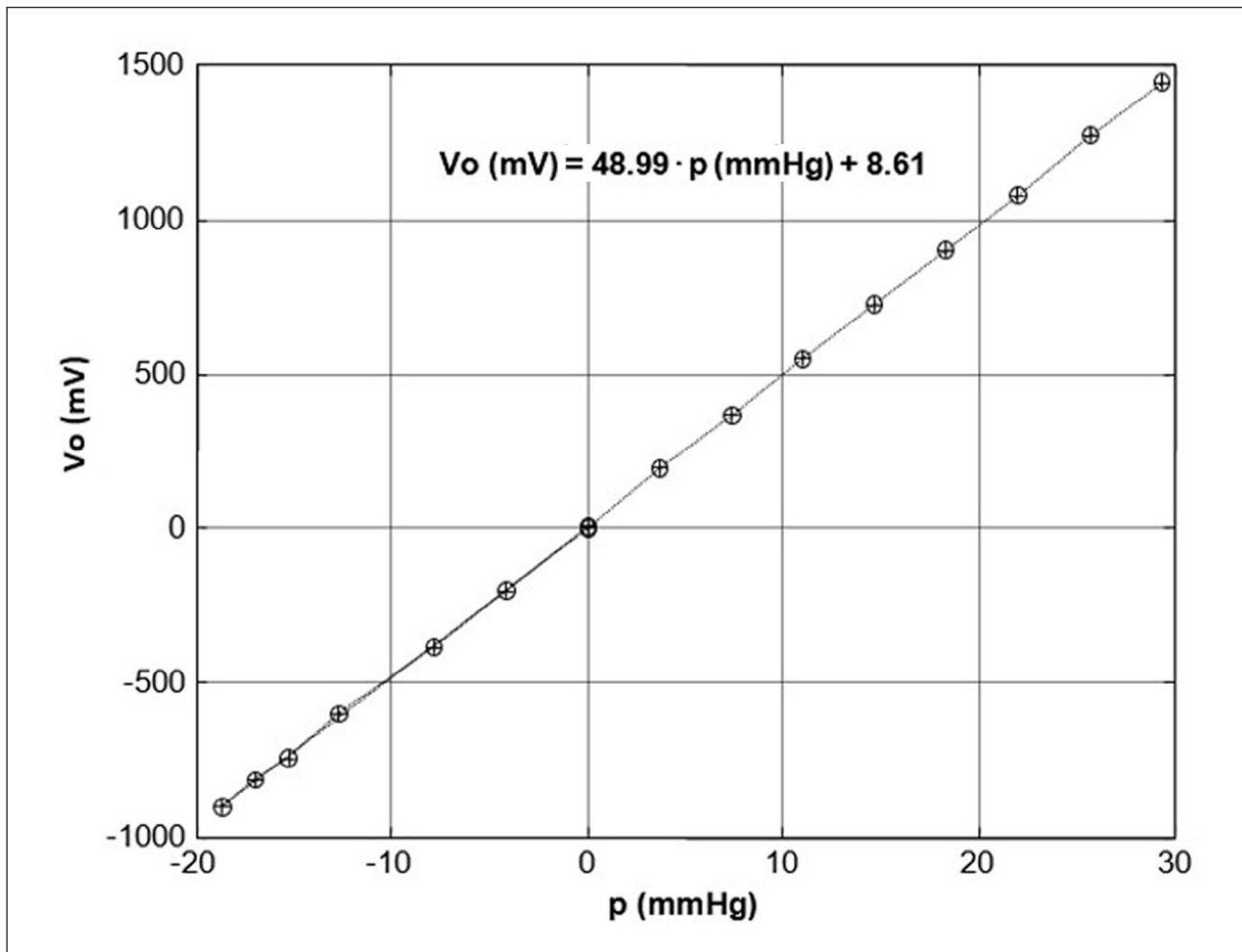

**Figure 3.** Measurement system calibration results.

the pressure measured and the output voltage is given by:

$$p = V_0 / 48.99 \text{ mmHg}$$

where  $V_0$  represents the output voltage of the conditioning circuit in mV.

The output signal from the measuring system is digitized by a BIOPAC A/D converter (MP 100) that includes a 16-bit A/D converter with an accuracy of greater than 0.003% of full-scale range (FS = 10 V). These characteristics of the BIOPAC A/D converter assure pressure measurement resolution of greater than 6  $\mu$ mHg. This resolution limitation is negligible relative to other error sources, such as the ones caused by positioning variations of the pacifier inside the newborns' mouth. NNS was sampled in 10 minute episodes that were converted into graphs in the AcqKnowledge 3.8 program, and it was possible to determine the temporal structure of NNS, i.e., the NNS behaviour of the newborn over time with regard to the following variables:

number and duration of bursts, number and duration of pauses between bursts, number of sucks per burst, frequency of suction (Hz), minimum and maximum pressure recorded and suction amplitude (mmHg). The data were stored and analysed in AcqKnowledge files, such as those shown in **Fig. 4**, which represent the measurement results for a 35-week GA baby. In order to increase measurement accuracy and to minimize noise effects, low-pass filtering capabilities of the BIOPAC equipment were used. As a reference for the mature NNS pattern, the standard pattern in healthy term newborns was considered.

We also used this device to record NS for one minute, and NS was obtained by administering milk through a probe attached to the teat of the pacifier placed in the mouth of the newborn. The milk was given at a constant rate of 1 ml/min via an infusion syringe. The probe used was a PVC enteral feeding tube, 40 cm in length and 5 Fr in diameter, attached to the pacifier with sterile Steri-Strip™ adhesive (**Fig. 1A** and **1C**).

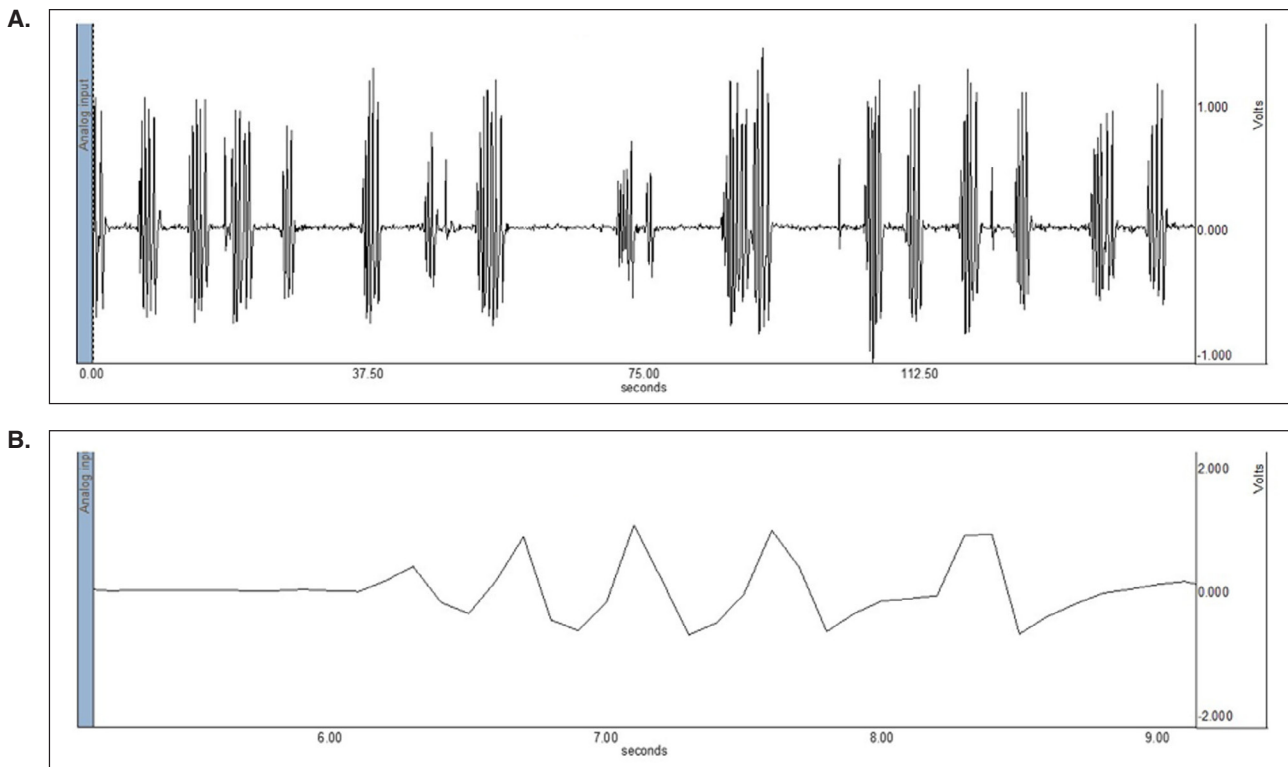

**Figure 4. A.** Non-nutritive sucking (NNS) pattern (multiple bursts). **B.** Second burst from **Fig. 4A** magnified. The x-axis shows the time in seconds and the y-axis shows the pressure range in volts.

### Data analysis

Statistical methods were used to compare the data from the two types of sucking (non-nutritive and nutritive) and between the two GA groups (preterm and term). For the comparison of the sucking patterns, the normality of the variables was assessed through Shapiro-Wilk tests, and then the differences between the mean values were examined using independent samples t tests. Regarding the comparison of the age groups, due to the very small number of term infants, nonparametric Mann-Whitney tests were used.

For statistical analysis, the IBM-SPSS® Software v. 22 was used. The statistical significance was set at  $p < 0.05$ .

The study was carried out in the NICU of a level III Baby-Friendly Hospital. It was approved by the hospital ethics committee, approval number 1012/2009, and informed consent was obtained from the parents of each newborn.

### Results

As previously mentioned, a convenience sample was used, whose demographic characteristics are shown in **Tab. 1**. At birth, the preterm group had

a mean GA of  $29.9 \pm 1.6$  weeks and a mean birth weight of  $1,258.7 \pm 271.8$  g, evaluated with a PCA of  $34.3 \pm 1.1$  weeks. The term group had a mean GA of  $39.5 \pm 1.4$  weeks and a mean birth weight of  $2,911.2 \pm 441.1$  g (**Tab. 1**).

We compared 570 bursts of NNS to 52 bursts of NS; there were statistically significant differences between the NNS and NS patterns in the majority of the different parameters evaluated (**Tab. 2**).

The NNS pattern, evaluated over a 10-minute period, was characterized by an average number of 35 bursts, but with relatively high variability, and the average number of pauses was 37, also with high variability. The NS pattern was examined for 1 minute only, and this methodological option restricts the use of the number of bursts and the number of pauses variables. The parameters for NNS and NS are different, with significant differences in the duration of the bursts ( $M = 4.3 \pm 2.2$  s vs  $13.9 \pm 7.0$  s;  $p < 0.001$ ), as well as the number of sucks per burst ( $M = 7.4 \pm 3.2$  vs  $16.9 \pm 7.7$ ;  $p < 0.001$ ), sucking frequency ( $M = 2.1 \pm 0.4$  Hz vs  $1.3 \pm 0.2$  Hz;  $p < 0.001$ ) and sucking pressure ( $M = 10.3 \pm 4.5$  mmHg vs  $13.7 \pm 3.9$  mmHg;  $p = 0.002$ ) (**Tab. 2, Fig. 5**). The duration of pauses did not present significant differences

**Table 1.** Sample demographic characteristics in median, interquartile range and frequency (%).

|                            | Preterm<br>n = 12               |         |         | Term<br>n = 4                   |         |         |
|----------------------------|---------------------------------|---------|---------|---------------------------------|---------|---------|
|                            | Median<br>(interquartile range) | Minimum | Maximum | Median<br>(interquartile range) | Minimum | Maximum |
| GA (weeks)                 | 29.8 (2.1)                      | 27.6    | 33.7    | 39.8 (2.7)                      | 37.6    | 41.0    |
| Birth weight (g)           | 1,420 (505)                     | 900.0   | 1,585.0 | 3,062 (773.8)                   | 2,270.0 | 3,250.0 |
| Prenatal steroids (%)      | 7 (58%)                         | -       | -       | NA                              | -       | -       |
| Apgar score                | 8.5 (3.25)                      | 6       | 10      | 10 (1.5)                        | 8       | 10      |
| IPVH $\leq$ grade III (%)  | 4 (33.3%)                       | -       | -       | 0                               | -       | -       |
| Time of ventilation (days) | 1 (9)                           | 0       | 9       | 0                               | -       | -       |
| Days of life               | 31.5 (15.3)                     | 10      | 54      | 2 (2.3)                         | 1       | 4       |
| Corrected age PCA (weeks)  | 34.5 (1.6)                      | 32.4    | 36.0    | 40.0 (2.4)                      | 37.8    | 41      |
| Time of experience (days)  | 20 (15)                         | 3       | 36      | 2 (2.3)                         | 1       | 4       |

GA: gestational age; PCA: postconceptional age; IPVH: intraperiventricular haemorrhage; NA: non applicable.

**Table 2.** Comparison of non-nutritive sucking (NNS) and nutritive sucking (NS) patterns.

|                                  | Mean $\pm$ SD   | Minimum | Maximum | CI 95%     | t test (NNS/NS)   |
|----------------------------------|-----------------|---------|---------|------------|-------------------|
|                                  |                 |         |         |            | p-value           |
| <b>NNS (10 min) = 570 bursts</b> |                 |         |         |            |                   |
| Bursts/min                       | 3.9 $\pm$ 1.4   | 1.8     | 6.2     |            | 0.41              |
| Bursts duration (s)              | 4.3 $\pm$ 2.2   | 2       | 11      | -12.9/-6.2 | <b>&lt; 0.001</b> |
| No. of pauses                    | 37.6 $\pm$ 12.5 | 16      | 63      | -          | -                 |
| Pauses duration (s)              | 10.8 $\pm$ 5.1  | 6       | 23      | -13.7/4.7  | 0.300             |
| No. of sucks per burst           | 7.4 $\pm$ 3.2   | 2.0     | 11.5    | -13.0/-5.8 | <b>&lt; 0.001</b> |
| Sucking frequency (Hz)           | 2.1 $\pm$ 0.4   | 1       | 3.0     | 0.1/0.6    | <b>&lt; 0.001</b> |
| Sucking pressure (mmHg)          | 10.3 $\pm$ 4.5  | 6       | 20.0    | -5.2/-1.4  | <b>0.002</b>      |
| <b>NS (1 min) = 52 bursts</b>    |                 |         |         |            |                   |
| Bursts/min                       | 3.2 $\pm$ 0.9   | 2       | 5       |            |                   |
| Bursts duration (s)              | 13.9 $\pm$ 7.0  | 3.0     | 29.0    |            |                   |
| No. of pauses                    | -               | -       | -       |            |                   |
| Pauses duration (s)              | 15.4 $\pm$ 18.3 | 4.0     | 69.0    |            |                   |
| No. of sucks per burst           | 16.9 $\pm$ 7.7  | 6       | 32      |            |                   |
| Sucking frequency (Hz)           | 1.3 $\pm$ 0.2   | 1       | 2       |            |                   |
| Sucking pressure (mmHg)          | 13.7 $\pm$ 3.9  | 8.0     | 21.0    |            |                   |

N = 16.

Significant differences ( $p < 0.05$ ) are bolded.

SD: standard deviation; NNS: non-nutritive sucking; NS: nutritive sucking.

( $M = 10.8 \pm 5.1$  s vs  $15.4 \pm 18.3$  s;  $p = 0.300$ ) (**Tab. 2**).

The comparison between the preterm ( $< 37$  weeks) and the term group (**Tab. 3**) in the NNS pattern, showed that only the sucking frequency was significantly lower in the term group ( $Md = 2.1$  Hz vs  $1.6$  Hz;  $p = 0.008$ ) (**Tab. 3**). However, in the NS pattern, significant differences were found between the two age groups in the duration of the bursts ( $Md =$

$10.0$  s vs  $20.5$  s;  $p = 0.020$ ) and in the number of sucks per burst ( $Md = 13.7$  vs  $27.1$ ;  $p = 0.004$ ), both higher in term newborns (**Tab. 3**). The study did not reveal significant differences between the two age groups in the sucking frequency ( $Md = 1.1$  Hz vs  $1.1$  Hz;  $p = 0.520$ ) or in the sucking pressure ( $Md = 15.7$  mmHg vs  $10.2$  mmHg;  $p = 0.058$ ), although a tendency is observed towards lower pressure values in term infants.

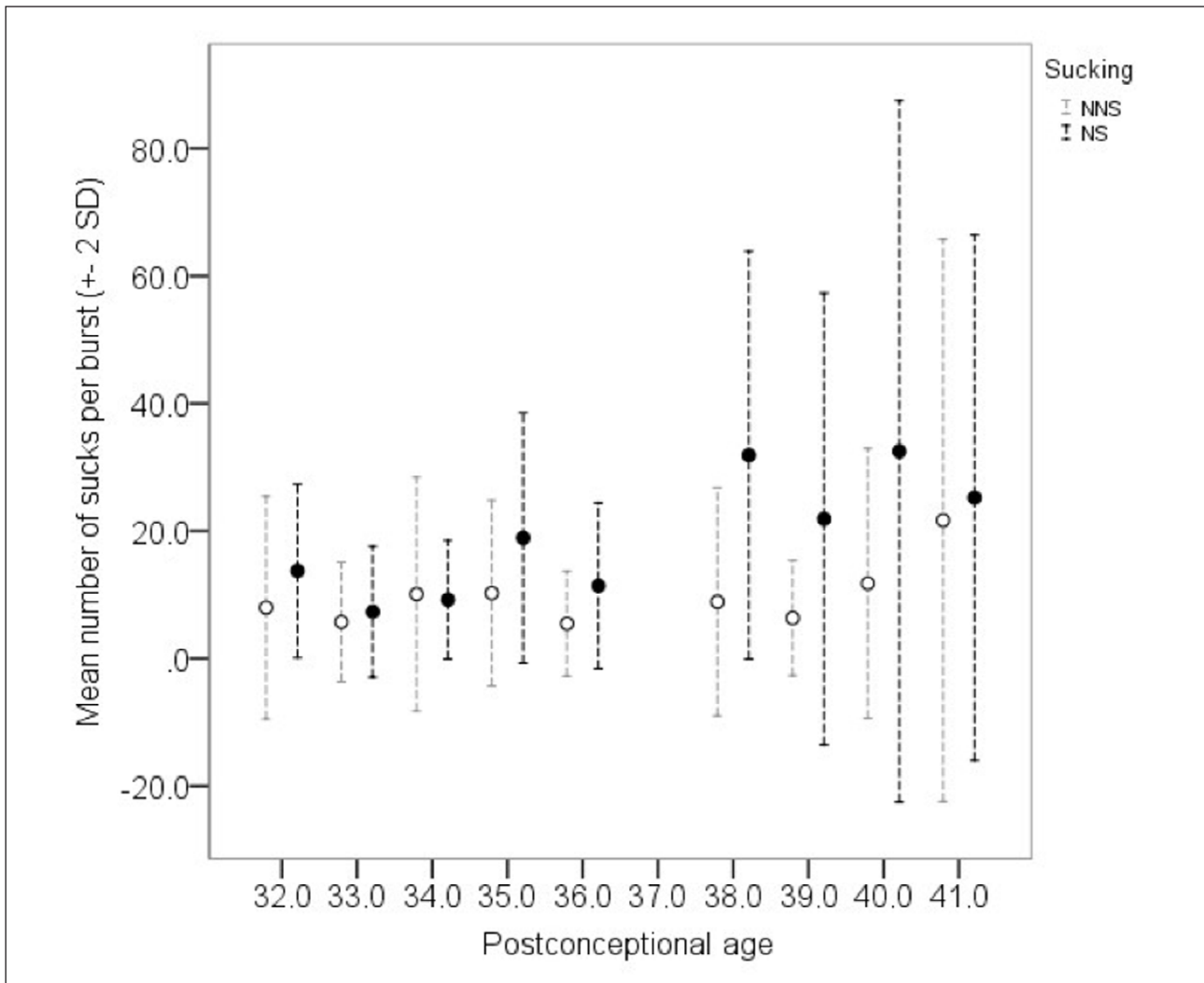

**Figure 5.** Non-nutritive and nutritive sucks per burst by postconceptional age (PCA). NNS: non-nutritive sucking; NS: nutritive sucking; SD: standard deviation.

**Table 3.** Comparison of preterm and term newborns regarding non-nutritive sucking (NNS) and nutritive sucking (NS) patterns.

|                           | Preterm / Term |            | M-W test     |
|---------------------------|----------------|------------|--------------|
|                           | Median         | Mean rank  | p-value      |
| Time of experience (days) | 20 / 2         | 10.3 / 2.8 | <b>0.002</b> |
| <b>NNS (10 min)</b>       |                |            |              |
| Bursts duration (s)       | 3.8 / 5.2      | 7.4 / 11.7 | 0.130        |
| Pauses duration (s)       | 37.5 / 33.0    | 8.2 / 9.2  | 0.770        |
| No. of sucks per burst    | 6.6 / 8.1      | 7.8 / 10.5 | 0.370        |
| Sucking frequency (Hz)    | 2.1 / 1.6      | 10.2 / 3.2 | <b>0.008</b> |
| Sucking pressure (mmHg)   | 9.7 / 7.5      | 9.1 / 6.5  | 0.370        |
| <b>NS (1 min)</b>         |                |            |              |
| Bursts duration (s)       | 10.0 / 20.5    | 6.9 / 13.1 | <b>0.020</b> |
| Pauses duration (s)       | 8.7 / 7.9      | 8.6 / 8.0  | 0.860        |
| No. of sucks per burst    | 13.7 / 27.1    | 6.6 / 14.0 | <b>0.004</b> |
| Sucking frequency (Hz)    | 1.1 / 1.1      | 9.0 / 7.0  | 0.520        |
| Sucking pressure (mmHg)   | 15.7 / 10.2    | 9.8 / 4.5  | 0.058        |

Significant differences ( $p < 0.05$ ) are bolded.

M-W test: Man-Whitney U Test; NNS: non-nutritive sucking; NS: nutritive sucking.



## Discussion

### *Sensor characteristics*

This study proposes an ecological, low-cost method to analyse the sucking pattern. The device developed is simple, non-invasive, and can easily be used with a normal pacifier usually present in nurseries for newborns [16, 24]. The proposed method allows both the NNS and NS to be measured. Even in less mature infants, it was possible to obtain a pressure threshold that allows sucks, bursts, and pauses in the sucking pattern to be identified, as described by Barlow et al. [14].

The method used to examine NS was the attachment of a nasogastric tube to the pacifier and the administration of milk through a syringe. The presence of milk induces the change into the NS pattern [13]. It is also possible to obtain the amount of milk sucked by introducing a tube into a bottle with a measured quantity of milk. This technique or “tube-pacifier” technique is an adaptation of the finger-feeding method that can be used to feed preterm newborns [25]. The use of the pacifier in this device complies with the recommendations for its use, even in the Baby-Friendly Hospital Initiative context [26]. Another option is to use the same approach as the one utilized by Chen et al. [27] with a silicone tube attached to the bottle teat or even to the breast, allowing the sucking pattern to be measured even when the baby is breastfed.

### *Differences between NNS and NS*

The method used to describe the NNS pattern was based on counting the sucks, the number of sucks per burst, inter-burst pauses and the pressure of suck, the same method as used by Barlow et al. [14] with the N-Trainer device, and more recently by Pineda et al. [28]. It seems a simpler method than others, such as the NOMAS scale [9] or the NNS used by Neiva et al. in 2014 [11], which needed at least 10 items to obtain a score. The sucking characteristics observed in the present study were similar to those reported by others and obtained by different methods [5, 6, 12, 14, 15, 29-31]. Similar results are described by Pineda et al. in a very recent publication [28].

The NNS pattern was similar to that obtained by Barlow et al. with the N-Trainer device [14, 31] in terms of the number of bursts per minute [14] and the number of sucks per burst [14, 31]. The sucking frequency of 2 Hz was the same as found

by ultrasound measurement of muscle thickness [12], nipple-bottle apparatus [15] and pressure measurement [30]. The positive values of pressure were similar to the values found by Mizuno and Ueda [30].

Concerning the NS pattern, the duration of the bursts was similar to those obtained by the nipple-bottle apparatus [15, 29] and nipple pressure transducer [6]. The sucking frequency of 1 Hz was also similar to that obtained by ultrasound measurement of muscle thickness [12], and other ultrasound measurements, as published by Geddes et al. [19, 32], as well as by the nipple-bottle apparatus [15], nipple pressure transducer and pressure measurement [6, 30]. The positive values of pressure were similar to the values found by the nipple-bottle apparatus [15] and pressure measurement [30]. Although we believe that the NS obtained through the method described may not be the same as the one used by the newborn on the breast or the teat, obtaining a suction pattern different from NNS with the same type of teat, triggered only by the presence of milk, can contribute to clarifying the NS mechanism and its dependence on milk flow.

The great advantage of this prototype is its low cost and ease of use compared to other devices or other suction measuring methods in newborns, which are expensive, need sophisticated materials (such as ultrasound) and require training and special skills. When in use, it also allows NNS, which has been shown to be an important stimulation method, improving the transition from gavage to oral feeding and decrease in hospital stays [17, 26].

As observed by Barlow [13], the emergence of the classic NNS burst-pause pattern is accompanied by a significant increase in the efficacy of NS. We found such an organization in the early GA beginning at 32 PCA weeks. This was accompanied by an efficient NS pattern that was significantly different from the NNS pattern in the duration of bursts, number of sucks per burst, frequency of sucking and power of suck. A more recent study also found that in preterm infants more stable sucking pressure in NNS over time was related to feeding success at 38 weeks PMA [28].

### *Differences between preterm and term newborns*

The comparison between preterm and term newborns showed different types of sucking patterns for NNS and also for NS. In the term newborns, there were longer NNS bursts with more sucks per burst, a lower power amplitude and a significantly

lower frequency. With the NS, considering the same amount of milk per minute (1 ml), preterm and term infants used different strategies: the preterm infants presented significantly shorter bursts with fewer sucks per burst, but with more power per suck than term newborns. These findings are consistent with the development process of NNS and NS patterns reported by Lau [3], but are somewhat contradictory to the results found by Capilouto et al. [12], who did not find significant differences between NNS and NS in preterm infants with the same PCA.

### Limitations

The major limitation of the study is the small number of newborns studied. However, if we consider that we have analysed all the sampling time, which was 10 minutes in NNS, and if we also take into account the total number of bursts analysed, 570 in NNS and 52 in NS, we can consider a reasonable value for analysis of the sucking pattern by the device tested, which was the main aim of the study.

In order to validate the values found for NS, it is necessary to use a larger sample with the adaptation of the “tube-pacifier” technique to the prototype described. This type of instrument, with a modification similar to that proposed by Chen et al. [27], will allow the study of NS in infants while breastfeeding, which is the recommended option even in premature infants [33, 34].

Data from the comparison between full-term and preterm infants should be interpreted with caution because of the small sample size of the term group, which, as mentioned, is one of the limitations of the study. The lack of validation with other suction self-report measures is another of the limitations, although these values are similar to those reported by different authors.

### Conclusion

The device tested seems to be adequate for measuring sucking parameters that can be used to describe NNS patterns in preterm and term newborns, as we obtained similar results to those referred to in other studies using different methods. It also allows the observation of changes in the sucking rhythm and pressure in the presence of milk, even in very immature newborns, suggesting different central pattern generators between NNS and NS and the importance of flow in this pattern.

At the same time, the use of the device pacifier promotes NNS, which is important in the process of acquiring feeding autonomy in preterm infants.

The ease of use of this device will allow the study of a large number of newborns, thus enabling the creation of an algorithm that will allow automatic analysis of the sucking pattern.

### Acknowledgements

Contributor and supporting agency: Sociedade Portuguesa de Neonatologia.

### Declaration of interest

This study was conducted on the application of a prototype developed by the Department of Instrumentation and Measurement, at ESTS/IPS (Escola Superior de Tecnologia de Setúbal, Instituto Politécnico de Setúbal, Setúbal, Portugal), whose patent has been registered. Three of the Authors (José Miguel Pereira, Vítor Viegas, Carlos Banha) work at ESTS/IPS.

The Authors declare that there are no other conflicts of interest.

### References

1. Medoff-Cooper B, McGrath JM, Shults J. Feeding patterns of full-term and preterm infants at forty weeks postconceptional age. *J Dev Behav Pediatr.* 2002;23(4):231-6.
2. Medoff-Cooper B, McGrath JM, Bilker W. Nutritive sucking and neurobehavioral development in preterm infants from 34 weeks PCA to term. *MCN Am J Matern Child Nurs.* 2000;25(2):64-70.
3. Lau C, Geddes D, Mizuno K, Schaal B. The Development of Oral Feeding Skills in Infants. *Int J Pediatr.* 2012;2012:572341.
4. Mizuno K, Ueda A. The maturation and coordination of sucking, swallowing, and respiration in preterm infants. *J Pediatr.* 2003;142(1):36-40.
5. Cunha M, Barreiros J, Gonçalves I, Figueiredo H. Nutritive sucking pattern-from very low birth weight preterm to term newborn. *Early Hum Dev.* 2009;85(2):125-30.
6. Qureshi MA, Vice FL, Taciak VL, Bosma JF, Gewolb IH. Changes in rhythmic suckle feeding patterns in term infants in the first month of life. *Dev Med Child Neurol.* 2002;44(1):34-9.
7. Amaizu N, Shulman R, Schanler RJ, Lau C. Maturation of oral feeding skills in preterm infants. *Acta Paediatr.* 2008;97(1):61-7.
8. Hafström M, Kjellmer I. Non-nutritive sucking in sick preterm infants. *Early Hum Dev.* 2001;63(1):37-52.
9. Palmer MM, Crawley K, Blanco IA. Neonatal oral-motor assessment scale: a reliability study. *J Perinatol.* 1993;13(1):28-35.
10. Thoyre SM, Shaker CS, Pridham KF. The Early Feeding Skills Assessment for Preterm Infants. *Neonatal Netw.* 2005;24(3):7-16.
11. Neiva FC, Leone CR, Leone C, Siqueira LL, Uema KA, Evangelista D, Delgado S, Rocha A, Buhler KB. Non-nutritive sucking evaluation in preterm newborns and the start of oral feeding: a multicenter study. *Clinics (Sao Paulo).* 2014;69(6):393-7.

12. Capilouto GJ, Cunningham T, Frederick E, Dupont-Versteegden E, Desai N, Butterfield TA. Comparison of tongue muscle characteristics of preterm and full term infants during nutritive and nonnutritive sucking. *Infant Behav Dev.* 2014;37(3):435-45.
13. Barlow SM. Oral and respiratory control for preterm feeding. *Curr Opin Otolaryngol Head Neck Surg.* 2009;17(3):179-86.
14. Barlow SM, Finan DS, Lee J, Chu S. Synthetic orocutaneous stimulation entrains preterm infants with feeding difficulties to suck. *J Perinatol.* 2008;28(8):541-8.
15. Fucile S, Gisel EG, Lau C. Effect of an oral stimulation program on sucking skill maturation of preterm infants. *Dev Med Child Neurol.* 2005;47(3):158-62.
16. Rocha AD, Moreira MEL, Pimenta HP, Ramos JRM, Lucena S. A randomized study of the efficacy of sensory-motor-oral stimulation and non-nutritive sucking in very low birthweight infant. *Early Hum Dev.* 2007;83(6):385-8.
17. Foster JP, Psaila K, Patterson T. Non-nutritive sucking for increasing physiologic stability and nutrition in preterm infants. *Cochrane Database Syst Rev.* 2016;10:CD001071.
18. Tamilia E, Taffoni F, Formica D, Ricci L, Schena E, Keller F, Guglielmelli E. Technological Solutions and Main Indices for the Assessment of Newborns' Nutritive Sucking: A Review. *Sensors (Basel).* 2014;14(1):634-58.
19. Geddes DT, Chooi K, Nancarrow K, Hepworth AR, Gardner H, Simmer K. Characterisation of sucking dynamics of breastfeeding preterm infants: a cross sectional study. *BMC Pregnancy Childbirth.* 2017;17(1):386.
20. Honeywell. Miniature Low Pressure Sensors. Available at: <http://www.alldatasheet.com>, last access: May 2017.
21. Test Equipment Depot. Ametek T-730 – Pneumatic Pressure Hand Pump. Available at: <http://www.testequipmentdepot.com/ametek/pressurepumps/t730.htm>, last access: May 2017.
22. ThermoFisher Scientific. Nalgene™ Repairable Hand-Operated PVC Vacuum Pumps with Gauge. Available at: <https://www.thermofisher.com/order/catalog/product/6132-0010>, last access: May 2017.
23. Meriam Instruments. Water Column 30EB25™. Available at: <http://www.meriam.com/product-category/manometers>, last access: May 2017.
24. Lau C, Schanler RJ. Oral feeding in premature infants: advantage of a self-paced milk flow. *Acta Paediatr.* 2000;89(4):453-9.
25. Carter C. Alternative feeding methods – cup or finger feeding (using a syringe or tube). NHS Foundation Trust. Available at: <http://www.royalberkshire.nhs.uk/patient-information-leaflets/maternity-alternative-feeding-methods---cup-or-finger-feeding.htm>, date of publication: 2018, last access: April 2019.
26. Lubbe W, ten Ham-Baloyi W. When is the use of pacifiers justifiable in the baby-friendly hospital initiative context? A clinician's guide. *BMC Pregnancy Childbirth.* 2017;17(1):130.
27. Chen L, Lucas RF, Feng B. A Novel System to Measure Infants' Nutritive Sucking During Breastfeeding: the Breastfeeding Diagnostic Device (BDD). *IEEE J Transl Eng Health Med.* 2018;6:2700208.
28. Pineda R, Dewey K, Jacobsen A, Smith J. Non-Nutritive Sucking in the Preterm Infant. *Am J Perinatol.* 2019;36(3):268-76.
29. Scheel CE, Schanler RJ, Lau C. Does the choice of bottle nipple affect the oral feeding performance of very-low-birthweight (VLBW) infants? *Acta Paediatr.* 2005;94(9):1266-72.
30. Mizuno K, Ueda A. Changes in Sucking Performance from Nonnutritive Sucking to Nutritive Sucking during Breast and Bottle-Feeding. *Pediatr Res.* 2006;59(5):728-31.
31. Barlow SM, Lee J, Wang J, Oder A, Hall S, Knox K, Weatherstone K, Thompson D. Frequency-Modulated Orocutaneous Stimulation Promotes Non-nutritive Suck Development in Preterm Infants with Respiratory Distress Syndrome or Chronic Lung Disease. *J Perinatol.* 2014;34(2):136-42.
32. Geddes D, Kok C, Nancarrow K, Hepworth A, Simmer K. Preterm Infant Feeding: A Mechanistic Comparison between a Vacuum Triggered Novel Teat and Breastfeeding. *Nutrients.* 2018;10(3):E376.
33. Lucas RF, Smith RL. When is it safe to initiate breastfeeding for preterm infants? *Adv Neonatal Care.* 2015;15(2):134-41.
34. Maastrup R, Hansen BM, Kronborg H, Bojesen SN, Hallum K, Frandsen A, Kyhnaeb A, Svarer I, Hallström I. Factors Associated with Exclusive Breastfeeding of Preterm Infants. Results from a Prospective National Cohort Study. *PLOS ONE.* 2014;9(2):e89077.